

Key Features

75" 4K Interactive Flat Panel

- > InGlass™ Technology for increased accuracy
- > FIPS201 certified fingerprint reader
- > 20-Point Multi-Touch
- > Dual Expansion PC Slots
- > Built-in ARM Quad-core CPU with 16GB Storage



Product Description

Featuring 4K Ultra HD resolution and an immersive InGlass™ touchscreen, the ViewSonic® ViewBoard® IFP7560 delivers incredible collaborative capabilities for 21st century boardrooms and classrooms. The highly accurate InGlass touch screen provides an incredibly natural handwriting experience, and allows multiple users to simultaneously write or draw on the 75" screen with their fingers and styluses. With a built-in quad-core processor, as well as versatile connectivity options including multiple HDMI, VGA, RS232, RJ45, and USB ports, this display provides powerful computing for annotation and multimedia playback without the need for a PC. The optional slot-in PC offers additional computing power for intensive interactive applications. The IFP7560 features a VESA-compatible design and can be placed on a wall mount, or on an optional trolley cart for flexible installation in classrooms and corporate meeting rooms.

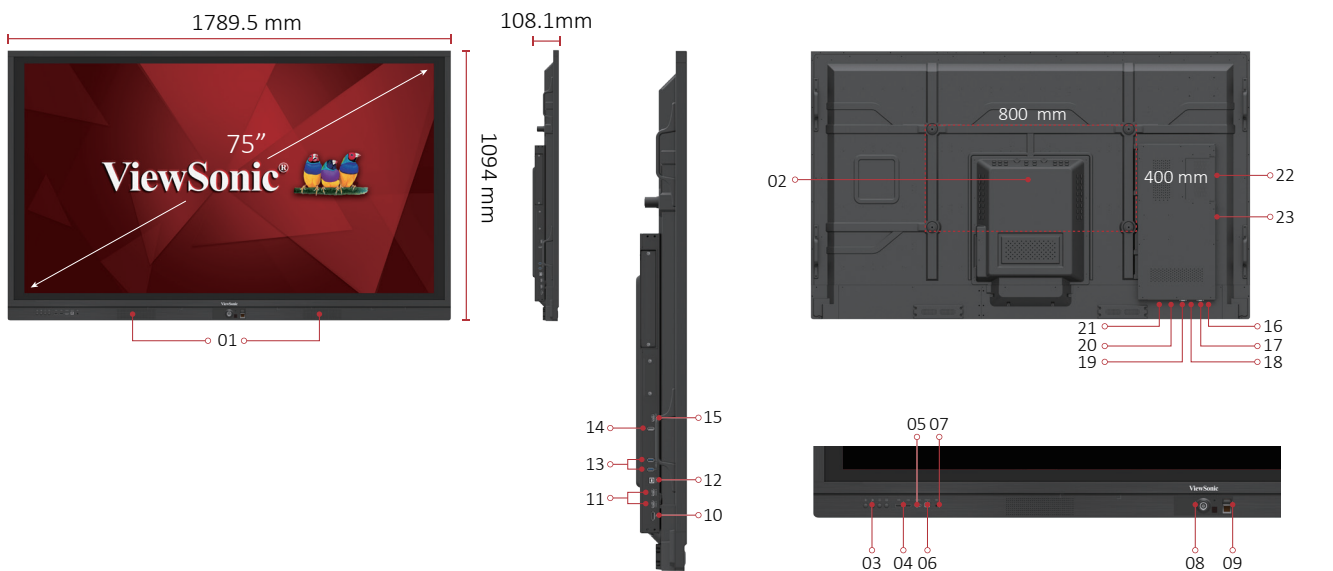

- 01. INTERNAL SPEAKERS
- 02. VESA® Wall Mount
800 x 400 mm
- 03. MENU CONTROLS
- 04. USB B TOUCH PORT
- 05. HDMI 1.4 IN
- 06. TOUCH

- 07. MIC
- 08. POWER ON / OFF
- 09. FIPS201 CERTIFIED
FINGERPRINT READER
- 10. DISPLAY PORT
- 11. HDMI 2.0 In X 2
- 12. USB TOUCH PORT

- 13. USB 3.0 X 2
- 14. USB 2.0
- 15. HDMI OUT
- 16. AUDIO IN
- 17. VGA IN
- 18. LAN

- 19. RS232 IN
- 20. SPDIF
- 21. EARPHONE
- 22. Intel Unite® Certified
OPS Slot
- 23. Intel Certified SDM Slot



75"



3840 x 2160



20 point-touch



350 nits



7H glass



10W (x2)

Display:

Display Size (in.):	75
Viewable Area (in.):	75
Light Source:	LED
Resolution:	3840 x 2160
Aspect Ratio:	16:9
Static Contrast Ratio:	4,000:1
Backlight Life (Hours):	30,000
Brightness:	350 nits
Response Time (Typical GTG):	8ms
Viewing Angles:	178° horizontal, 178° vertical
Panel Surface:	Anti-glare 7H tempered glass

Embedded Player:

Android Version:	5.01
GPU:	ARM Mali450 MP4
CPU:	ARM Quad Core Cortex A53
CPU Processor Speed:	1.4GHz
Memory:	2GB
Storage:	16GB
Interface:	OSD / Remote Control / Annotation overlay
Ethernet LAN:	10/100 Mbps

Audio:

Internal Speakers:	10W (x2)
--------------------	----------

Connector:

HDMI 1.4(1), HDMI 2.0(2), HDMI Out(1), VGA(1), Display Port(1), 3.5mm Audio In(1), 3.5mm Audio Out(1), USB 3.0(2), USB 2.0(3), OPS PC Slot(1), USB B Touch Port(2), RS232(1), Ethernet LAN (RJ45)(1), SDM Slot(1)

Power:

Voltage:	100-240 VAC
Consumption (typical):	310W
Stand-by:	<0.5W

Controls:

On Screen Display:	Input, Volume, Backlight, Audio, Screen, Display, Adjust
Remote Control:	Volume, Channel, Source, Mute, Back, Input, Menu

Operating Conditions:

Temperature:	32-104° F (0- 40° C)
Humidity (non-condensing):	10-90%

Touch:

Touch Technology:	InGlass
Touch Points:	20-Point Touch

Weight (metric):

Net (kg):	62.0
Gross (kg):	80.3

Weight (imperial):

Net (lbs):	136.7
Gross (lbs):	177.0

Dimensions (metric) (WxHxD):

Packaging (mm):	1945.0 x 1230.0 x 280.0
Physical (mm):	1789.5 x 1094.5 x 108.1

Dimensions (imperial) (WxHxD):

Packaging (in.):	76.6 x 48.3 x 11.0
Physical (in.):	70.5 x 43.1 x 4.3

Mount:

VESA Compatible:	800 x 400 mm
------------------	--------------

Warranty:

3-year limited warranty on parts, labor and backlight, onsite warranty

Recycle/Disposal:

Please dispose of in accordance with local, state or federal laws.

What's In The Box?

IFP7560 Display, Stylus Pen x 2, Power Cable, Remote Control with Batteries, Quick Start Guide, Camera Plate, USB Cable, HDMI Cable

Regulations:

cTUVus, FCC, ENERGY STAR 7.0, Mexico Energy, CE, CB, RoHS, ErP, WEEE

UPC:

766907963618

Accessories:

CD-EW-70-01, CD-EW-70-02, LB-STND-005-3, NMP660, SW-043, SW-044, SW-071-2, SW-072-2, SW-073-2, SW-074-2, SW-075-2, SW-101, SW-110, SW-111, SW-UP-117, VB-STND-001, VB-STND-002, VB-STND-003, VB-STND-004, VB-VIS-001, VPC12-WPO, VPC12-WPO-2, WMK-047-2
